

# PREXISO

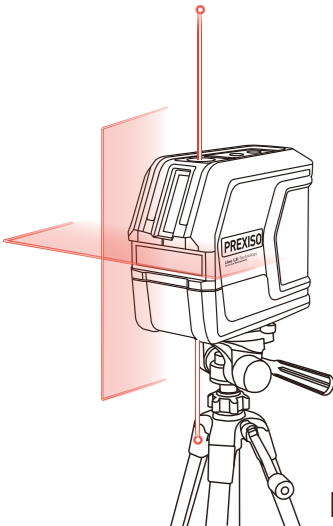

P2LC15T

## CROSS LINE LASER LEVEL WITH PLUMB POINTS WITH TRIPOD



www.prexiso-eu.com  
P2LC15T-05REV01-2406

### SAFETY INSTRUCTIONS

Working safely with the measuring tool is possible only when the operating and safety information are read completely and instructions contained herein are strictly followed. Never make warning labels on the measuring tool unrecognizable. **SAVE THESE INSTRUCTIONS.**

Caution – The use of operating or adjusting equipment or the application or processing methods other than those mentioned herein, can lead to hazardous radiation exposure.



### WARNING

**LASER RADIATION.** Do not stare into beam. Class II consumer laser product. Turn the laser beam on only when using this tool.

- **Do not remove or deface any product labels.**
- **Avoid direct eye exposure.** The laser beam can cause persons being blinded.
- **Do not** operate the tool around children or allow children to operate the tool.
- **Do not** place the tool in a position that may cause anyone to stare at the laser beam, whether intentionally or unintentionally.
- **Do not** use on reflecting surfaces such as sheet steel, glass or polished metal etc. that have shiny, reflective surfaces. The shiny surface could reflect the beam back at the operator.
- **Always turn the laser tool off when not in use.** Leaving the tool on increases the risk of someone inadvertently staring into the laser beam
- **Do not** attempt to modify the performance of this laser device in any way. This may result in a dangerous exposure to laser radiation.
- **Do not** attempt to repair or disassemble the laser-measuring tool. If unqualified persons attempt to repair this product, serious injury may occur. Any repair required on this laser product should be performed only by qualified service personnel.
- Use of other accessories that have been designed for use with other laser tools could result in serious injury.
- **Do not** operate the tool outdoors.

- **Do not** place or store tool under extreme temperature conditions.
- **Do not** operate the tool in explosive environments, such as in the presence of flammable liquids, gases or dusts. Sparks can be created in the tool which may ignite the dust or fumes.
- Keep the tool **away from** cardiac pacemakers. The magnet inside the tool generates a field that can impair the function of cardiac pacemakers.
- Keep the tool **away from** magnetic data medium and magnetically-sensitive equipment. The effect of the magnetic can lead to irreversible data loss.
- Measurement **may not** be accurate if used beyond the rated range of the device.
- The use of optical instruments with this product will increase eye hazard.
- **Always** make sure any bystanders nearby aware of the dangers of looking directly into the measuring tool.
- **Do not** use the laser viewing glasses as safety goggles, they do not protect eyes against laser radiation.
- **Always** remove the batteries when cleaning the laser light aperture to laser lens.
- **Always** remove the batteries if you are not using the instrument for a long time. Ensure that the battery polarity connections are correct when replacing batteries.

### TECHNICAL SPECIFICATIONS

COMPONENT	SPECIFICATIONS
Laser	$\lambda=620-690$ nm, Class 2 laser, maximum laser output<1mW
Operating range (typically)	20M(65FT)
Accuracy (typically)	$\pm 3\text{mm}@10\text{M}$ ( $\pm 1/8"$ @32ft )
Self-leveling range	$\pm 4^\circ$
IP rating	IP54
Estimated battery life	>10 hours (alkaline batteries)
Optimum operating temperature	32°F to 104°F (0°C to 40°C)
Storage temperature	14°F to 140°F (-10°C to 60°C)
Batteries	3 x 1.5V alkaline AA

\*Important: The accuracy is rated within distance of 10 meters. Under unfavorable conditions, such as in extreme interior illumination, transparent surfaces (eg. glass, water), porous surfaces (eg. insulation materials) or reflecting surfaces (eg. polished metal, glass) or very rough surfaces (eg. rough cast, natural stone), the tool's measuring range and accuracy will be reduced.

### DESCRIPTION

#### CROSS LINE LASER LEVEL WITH PLUMB POINTS

This self-leveling cross line laser is a highly versatile tool. It can be placed on the ground, mounted on a door frame or work bench etc. when use the appropriate accessories eg. wall mount, tripod etc. but not limited.

- Self-leveling levels within  $+4$  degrees to  $-4$  degrees with an accuracy of  $\pm 3\text{mm}@10\text{M}$  ( $\pm 1/8"$  @32ft ).
- AA alkaline batteries.

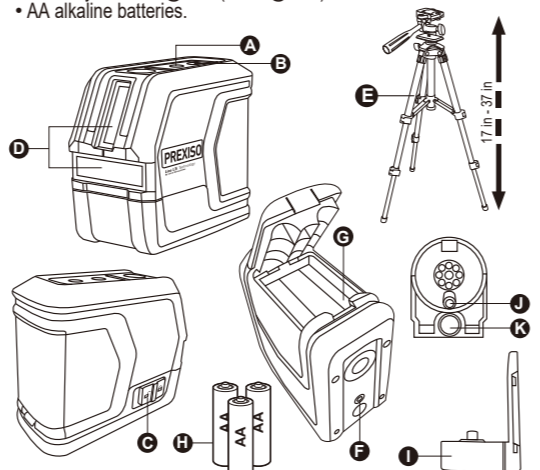

PARTS	DESCRIPTION
A	Power / Mode button
B	Pulse mode button
C	Lock / Unlock switch
D	Laser aperture
E	Tripod with 1/4" screw, up to 37in./0.94m
F	1/4"-20 threaded mounting hole
G	Battery compartment latch
H	AA batteries
I	Magnetic mounting bracket
J	1/4" threaded mounting hole on bracket
K	5/8" threaded mounting hole on bracket

### UNPACKING

When unpacking the box, do not discard any packing materials until all of the contents are accounted for:

- Self-Leveling Cross Line Laser Tool
- Magnetic mounting bracket
- Tripod up to 37in./0.94 m
- 3 x AA alkaline batteries
- Operator's manual

Carefully lift the compact laser measuring tool out of the package and place it on a stable, flat surface.

### ASSEMBLY

#### INSERTING/REPLACING THE BATTERY

AA alkaline batteries are recommended for the measuring tool.

To open the battery compartment lid, press the latch and open it. Insert the batteries provided. Pay attention to the correct polarity of the batteries according to the representation on the metal plate inside the lid.

Always replace all batteries at the same time. Only use batteries from one brand and with the identical capacity.

**NOTE:** Remove the batteries from the measuring tool when not using it for extended periods. When storing for extended periods, the batteries can corrode and discharge themselves.

### OPERATION

#### 1. TO TURN THE SELF LEVELING CROSS LINE LASER ON AND OFF

The power switch is located on the bottom at the side of the tool.

- To turn the compact self-leveling cross line laser on, push the power switch in the direction of the "☐" side.

**WARNING:** When turning on the self-leveling cross line laser, always be aware of protecting your eyes and the eyes of those around you. Never point the compact self-leveling cross line laser at anyone's face, including your own.

- To turn the tool off, slide the switch in the direction of the "☒" side.

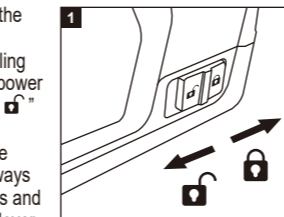

### 2. LASER LINE PROJECTION MODES

The self-leveling cross line laser has three laser-projection modes. To select a specific laser projection mode, press the "Ⓢ" button until you get the desired projection mode. The laser tool defaults to work on cross line with plumb points when turned on.

To choose a projection mode, press the mode button:

- Press the "Ⓢ" button once to select the horizontal laser line.
- Press the "Ⓢ" button twice to select the vertical laser line and two point laser.
- Press the "Ⓢ" button three times to the cross line pattern and two point laser.

### 3. LEVELING MODES

The self-leveling cross line laser has two leveling modes: self-leveling mode and lock (manual) mode.

3.1 In self-leveling mode, the tool will level itself if it is within  $\pm 4^\circ$  of horizontal.

- Place the self-leveling cross line laser on a flat, smooth surface that is within  $\pm 4^\circ$  of horizontal.
- Turn the tool on by sliding the power switch to the "☐" side. The self-leveling cross line laser will automatically level within 4 seconds.
- Press the "Ⓢ" button until the desired laser-projection mode is achieved.
- If the surface on which the self-leveling cross line laser is placed exceeds  $\pm 4^\circ$  from horizontal the "Ⓢ" LED turns red and the laser line will blink with 5Hz frequency as an alarm. In this case, adjust the angle of the surface slightly, and the lines will be stable again and the red light goes off.

### 4. LOCK (MANUAL) MODE

This mode cannot be used to perform horizontal or vertical leveling, because the laser lines are no longer self leveling. In this mode, the "Ⓢ" LED turns red.

- Slide the "☐☒" switch to "☒" side and press the "Ⓢ" button 3sec to turn on the laser. The laser lines are now locked and no longer functions self-leveling.
- Press the "Ⓢ" button to change the laser-projection mode.
- Slope the self-leveling cross laser to project a straight line for reference of your project.

### 5. BUILT-IN PULSE MODE (LASER RECEIVER NOT INCLUDED)

This laser tool defaults with built-in pulse mode (10KHZ) for laser receiver. Press "Ⓢ" to activate or deactivate pulse mode and the green light indicates if the pulse mode is on. Working with a laser receiver, the working range can be extended to 164ft/50m maximum.

### 6. USING WITH THE CLAMP, WALL MOUNT OR TRIPOD

The laser tool is equipped with a magnetic bracket and can be easily fixed on flat metal surfaces. At the bottom of the tool, a 1/4"-20 nut is located. Mount the tool to accessories like clamp, wall mount or tripod by assembling the tool nut with the 1/4"-20 screw on the accessories. With the accessories, the tool can work under various applications which makes jobs done easier.

**Note:**  
**Make sure the tool can be assembled on the accessories without damage or interference to any part of the self-leveling cross line laser or the accessories.**

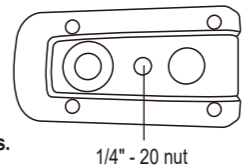

### 7. APPLICATIONS

- The self-leveling cross line laser can be placed on the ground, mounted on a work bench / door frame etc. for point marking and simple alignment by sight. It is ideal for the following applications:
- Hanging pictures, photos, or artwork on walls
  - Wallpapering and stencil work
  - Framing doors and windows
  - Installing electrical wiring and pipes
  - Mounting wall fixtures, electrical outlets, switches and lighting
  - Installing a drop ceiling
  - Painting
  - Installing cabinets
  - Laying tile and flooring

### MAINTENANCE

This laser measuring tool has been designed to be a low-maintenance tool. However, in order to maintain its performance, you must always follow these simple directions:

- **Avoid** exposing the tool to shock, continuous vibration or extreme hot or cold environment.
- **Always** store the tool indoors.
- **Always** keep the tool free of dust and liquids. Use only a clean soft cloth for cleaning. If necessary, slightly moisten the cloths with pure alcohol or a little water.
- **Do not** disassemble the laser measuring tool, this will expose the user to hazardous radiation exposure.
- **Do not** attempt to change any part of the laser lens.

### TROUBLESHOOTING

PROBLEM	CAUSE	SOLUTION
The laser line projection is weak.	Batteries are weak.	Replace with new batteries.
The laser line is hard to see.	The tool is out of the rated operating range	Move the tool closer to be within the rated operating range.
Laser line is not projected.	No batteries installed or batteries are depleted.	Install new batteries.
Laser line flickers for alert.	The surface where the tool has been placed is uneven or the tool is working under manual mode.	Place the tool on flat surface levels within +/-4 degrees.

### DISPOSAL

#### CAUTION

The batteries must not be disposed with household waste. Care for the environment and take them to the collection points provided in accordance with national or local regulations. Dispose of the product appropriately in accordance with the national regulations in force in your country. Adhere to the national and country specific regulations. Product specific treatment and waste management can be downloaded from our homepage.

#### WARRANTY

Two-Year Limited Warranty. This product is warranted to the original purchaser from the original purchase date for two years subject to the warranty coverage described herein. Please retain your receipt. This product is warranted to the original user to be free from defects in material and workmanship. If you believe that the product is defective at any time during the specified warranty period, please contact Prexiso customer service agent by sending email to info@prexiso-eu.com. This warranty does not cover: (1) Part failure due to normal wear or product abuse; (2) Any parts have been altered or modified by anyone other than an authorized Prexiso personnel or failure to install and operate equipment according to the guidelines put forth in the instruction manual. (3) Any products or parts used for rental purposes, damage resulting from shipping (claims must be filed with freighter), accident, abuse, act of God, misuse, or neglect. Prexiso will replace or repair the defective unit, at its option, subject to verification of the defect. Any implied warranties arising from the sale of a Prexiso product, including but not limited to implied warranties of merchantability and fitness for a particular purpose, are limited to the above. Prexiso shall not be liable for loss of use of the product or other incidental or consequential damages, expenses, or economic loss, or for any claim of such damage, expenses, or economic loss. This warranty excludes any accessories. This warranty gives you specific legal rights, and you may also have other rights that vary from state.



Prexiso AG  
Fabrikstrasse 1  
CH-8586 Erlen / Switzerland