

**IMPORTANT:** Read before Using

# PREXISO<sup>®</sup> P100GD

## RECHARGEABLE GREEN-BEAM LASER DISTANCE MEASURE

---

**330FT**  
**100M**

**2** LIMITED  
YEARS WARRANTY

[www.prexiso-eu.com](http://www.prexiso-eu.com)

P100GD-05REV01-2312



## Table of Contents

<b>Instrument Set-up</b> .....	<b>2</b>	<b>Safety Instructions</b> .....	<b>11</b>
Overview .....	2	Symbols used .....	11
Display .....	2	Permitted use .....	11
Charge the device .....	2	Prohibited use .....	11
<b>Operations</b> .....	<b>3</b>	Hazards in use .....	11
Switching ON/OFF .....	3	Limits of use .....	11
Unit setting .....	3	Areas of responsibility .....	12
Measurement reference .....	3	Electromagnetic Compatibility (EMC) .....	12
<b>Functions</b> .....	<b>4</b>	FCC statement (applicable in U.S.) .....	12
Measuring single distance .....	4	Laser classification .....	12
Continuous measuring .....	4	<b>Warranty</b> .....	<b>13</b>
Sound .....	4		
Area .....	5		
Volume .....	5		
Height difference measure .....	6		
Pythagoras .....	7		
Clear .....	7		
Addition/Subtraction .....	8		
Bubble Vial .....	8		
Memory .....	8		
Angle measurement .....	9		
<b>Technical Data</b> .....	<b>10</b>		
<b>Message Codes</b> .....	<b>10</b>		
<b>Care</b> .....	<b>10</b>		
<b>Disposal</b> .....	<b>10</b>		

Overview

 The safety instructions and the user manual should be read through carefully before the product is used for the first time.

The person responsible for the product must ensure that all users understand these directions and adhere to them.

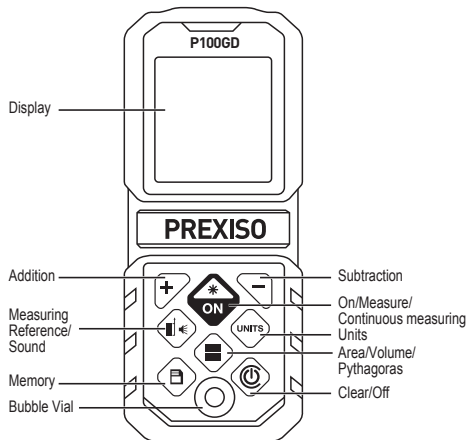

Display

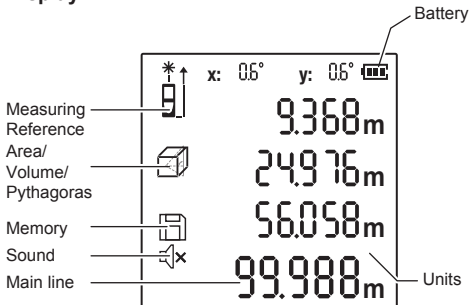

Charge the device

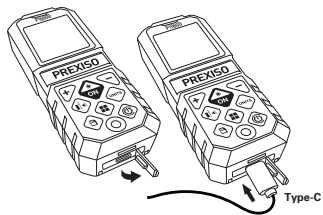

 Open the cap and insert the USB recharging cable with Type-C Port

Recharge the device when it is low battery



## Operations

### Switching ON / OFF



ON



OFF

3 sec

Device is turned OFF.



If no key is pressed for 120 sec, the device switches off automatically.

If the info icon appears with a number, observe the instructions in section "Message Codes".

Example:



Err16

## Unit setting



Switch between the following units:

0'00" 1/16

0 1/16 in

0.00 ft

0.000 m

## Measurement reference

1

The system default measurements start at the bottom as a reference point.

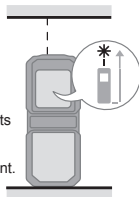

2

Press button to change the reference to tripod point for measurement.

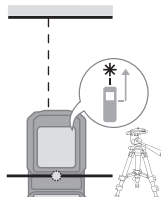

3

Press button to change the reference to top for measurement.

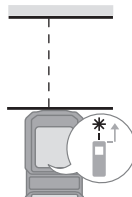

## Functions

### Measuring single distance

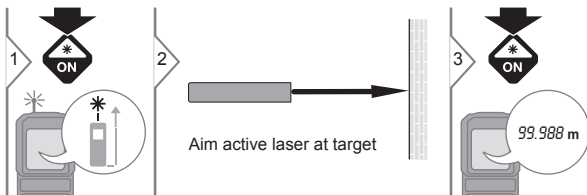

i

Target surfaces: Measuring errors can occur when measuring to colourless liquids, glass, styrofoam or semi-permeable surfaces or when aiming at high gloss surfaces. Against dark surfaces the measuring time increases.

### Continuous measuring

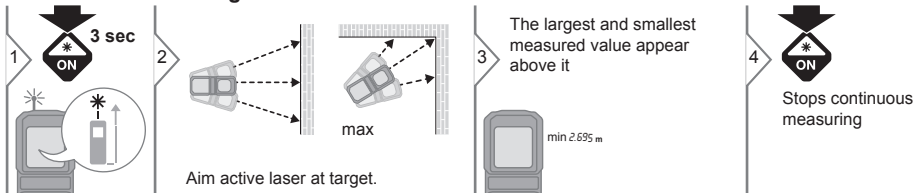

### Sound

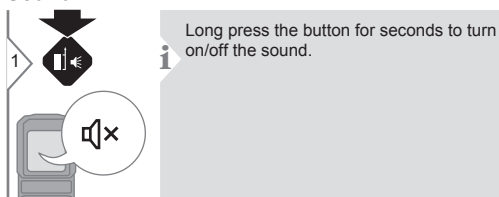

## Area

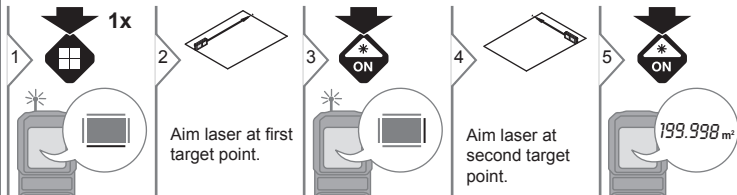

The result is shown in the main line and the measured distance above.

## Volume

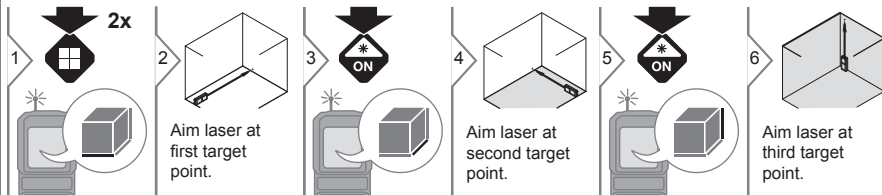

The result is shown in the main line and the measured distance above.

## Height Difference Measure (1 Point)

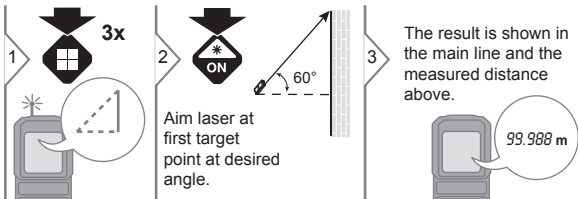

## Height Difference Measure (2 Point)

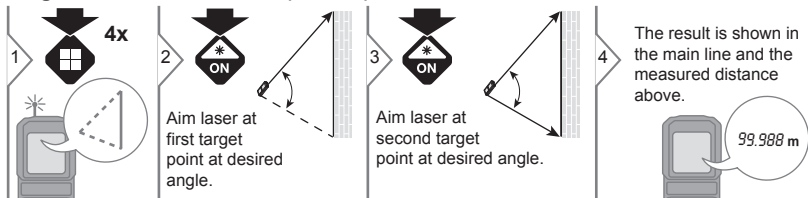

## Pythagoras

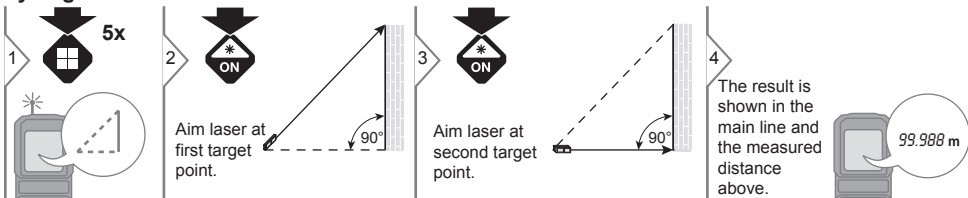

## Pythagoras

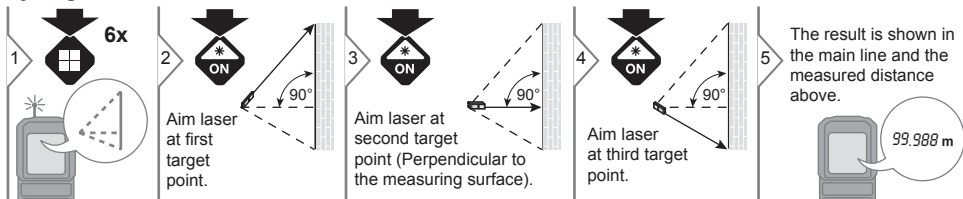

## Pythagoras

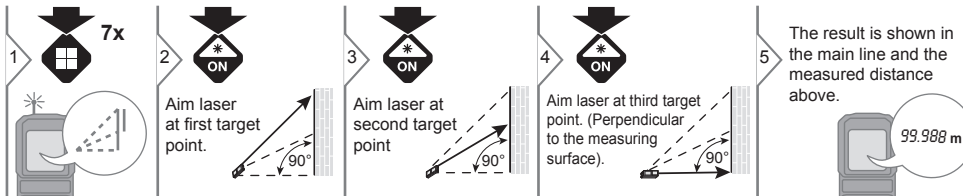

## Clear









## Addition/subtraction

- 



1 Measure the first data.

- 

2 Press button "+" to add or press button "-" to subtract next measurement from the previous data.

- 

3 Then measure the second data.

- 

4 The result is shown in the main line and the measured distance above.

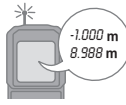
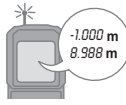



## Bubble Vial



- 

1 Built-in bubble vial enables a visual reference for horizontal alignment.

## Memory

- 

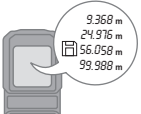
1



- 

2

The last 30 measurements are automatically stored.

Up towards the memory



Down towards the memory
- 

3

Delete the memory.



## Angle measurement

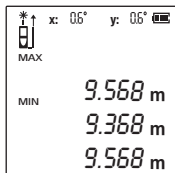

1

Angle measurements will display on the top of the screen with two values of X and Y. X refers to vertical direction angle value, and Y refers to horizontal direction angle value, useful for leveling alignment reference.

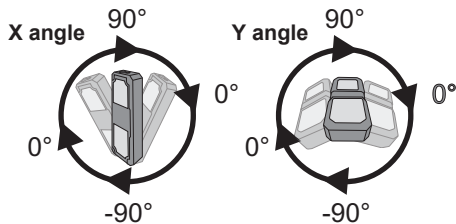

2

Inclination measurement is used to measure a slope or incline when laying the device on certain surface, (e. g stairs, railings, when fitting furniture, laying pipes, etc. ) also to measure the slope of some broken surfaces.

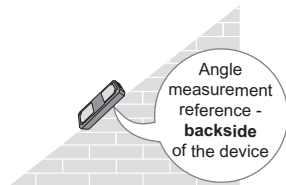

## Technical Data

General	
Range	0.05 - 100 m
	0.16 - 330 ft
Measuring accuracy*	± 3 mm
	± 1/8 in
Smallest unit displayed	1 mm
	1/16 in
Laser class	2
Laser type	500 nm - 550 nm
Autom. power switch-off	after 120 s
Continuous measuring	yes
Area / Volume	yes
Power supply	Li-ion battery
Recharging time	< 3 h
Battery service life in measuring operation, approx.	5h
Dimension(LxWxH)	119 x 48 x 26.5 mm
	4.7 x 1.9 x 1.0 in
Weight (without batteries)	107 g / 3.77 oz
Temperature range:	-10 to 60 °C
	14 to 140 °F
- Storage	
- Operation	0 to 40 °C
	32 to 104 °F

\* The typical measurement uncertainty of ± 3 mm is valid for measurements on white, diffusive, reflective targets up to 5 m at low ambient light and moderate temperatures. For distances greater than 5 m, the measurement uncertainty could increase additionally by 0.1 mm/m. In unfavourable conditions (such as bright sunlight, targets with poor reflectivity, or high or low temperatures) the measurement uncertainty could further increase up to ± 8 mm for distances below 5 m and additionally by roughly 0.15 mm/m for distances greater than 5 m.

## Message Codes

If the message Error does not disappear after switching on the device repeatedly, contact the dealer.

If the message InFo appears with a number, press the Clear button and observe the following instructions:

No.	Cause	Correction
Err10	Low battery	Recharge the battery
Err15	Out of measuring range	Correct range
Err16	Received signal too weak or measuring time too long	Change target surface (e.g. white paper) and remeasure
	Too much background light	Shadow target area
Err26	The results out of maximal digit on screen	Get the results by changing units or calculate manually

## Care

- Clean the device with a damp, soft cloth.
- Never immerse the device in water.
- Never use aggressive cleaning agents or solvents.

## Disposal

### CAUTION

The battery must not be disposed of with household waste. Care for the environment and take them to the collection points provided in accordance with national or local regulations. The product must not be disposed with household waste. Dispose of the product appropriately in accordance with the national regulations in force in your country. Adhere to the national and country specific regulations. Product specific treatment and waste management can be downloaded from our homepage.



Lithium

## Safety Instructions

The person responsible for the instrument must ensure that all users understand these directions and adhere to them.

### Symbols used

The symbols used have the following meanings:

#### WARNING

Indicates a potentially hazardous situation or an unintended use which, if not avoided, will result in death or serious injury.

#### CAUTION

Indicates a potentially hazardous situation or an unintended use which, if not avoided, may result in minor injury and/or appreciable material, financial and environmental damage.

**i** Important paragraphs which must be adhered to in practice as they enable the product to be used in a technically correct and efficient manner.

### Permitted use

- Measuring distances

### Prohibited use

- Using the product without instruction
- Using outside the stated limits
- Deactivation of safety systems and removal of explanatory and hazard labels
- Opening of the equipment by using tools (screwdrivers, etc.)
- Carrying out modification or conversion of the product
- Use of accessories from other manufacturers without express approval
- Deliberate dazzling of third parties; also in the dark
- Inadequate safeguards at the surveying site (e.g. when measuring on roads, construction sites, etc.)
- Deliberate or irresponsible behaviour on scaffolding, when using ladders, when measuring near machines which are running or near parts of machines or installations which are unprotected
- Aiming directly in the sun

### Hazards in use

#### WARNING

Watch out for erroneous measurements if the instrument is defective or if it has been dropped or has been misused or modified. Carry out periodic test measurements. Particularly after the instrument has been subject to abnormal use, and before, during and after important measurements.

#### CAUTION

Never attempt to repair the product yourself. In case of damage, contact a local dealer.

#### WARNING

Changes or modifications not expressly approved could void the user's authority to operate the equipment.

### Limits of use

**i** Refer to section "Technical data".  
**i** The device is designed for use in areas permanently habitable by humans. Do not use the product in explosion hazardous areas or in aggressive environments.

## Safety Instructions

### Areas of responsibility

#### Responsibilities of the person in charge of the instrument:

- To understand the safety instructions on the product and the instructions in the User Manual.
- To be familiar with local safety regulations relating to accident prevention.
- Always prevent access to the product by unauthorised personnel.

### Electromagnetic Compatibility (EMC)

#### WARNING

The device conforms to the most stringent requirements of the relevant standards and regulations. However, the possibility of causing interference in other devices cannot be totally excluded.

### FCC statement (applicable in U.S.)

This equipment has been tested and found to comply with the limits for a Class B digital device, pursuant to part 15 of the FCC Rules. These limits are designed to provide reasonable protection against harmful interference in a residential installation. This equipment generates, uses and can radiate radio frequency energy and, if not installed and used in accordance with the instructions, may cause harmful interference to radio communications.

However, there is no guarantee that interference will not occur in a particular installation. If this equipment does cause harmful interference to radio or television reception, which can be determined by turning the equipment off and on, the user is encouraged to try to correct the interference by one or more of the following measures:

- Reorient or relocate the receiving antenna.
- Increase the separation between the equipment and receiver.
- Connect the equipment into an outlet on a circuit different from that to which the receiver is connected.
- Consult the dealer or an experienced radio/TV technician for help.

## Safety Instructions

### Laser classification

The device produces visible laser beams, which are emitted from the instrument: It is a Class 2 laser product in accordance with:

IEC60825-1 : 2014 "Radiation safety of laser products"

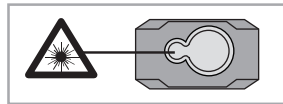

#### Laser Class 2 products:

Do not stare into the laser beam or direct it towards other people unnecessarily. Eye protection is normally afforded by aversion responses including the blink reflex.

#### WARNING

Looking directly into the beam with optical aids (e.g. binoculars, telescopes) can be hazardous.

## WARRANTY

Two-Year Limited Warranty. This product is warranted to the original purchaser from the original purchase date for two years subject to the warranty coverage described herein. Please retain your receipt. This product is warranted to the original user to be free from defects in material and workmanship. If you believe that the product is defective at any time during the specified warranty period, pls contact Prexiso customer service agent by sending email to [info@prexiso-eu.com](mailto:info@prexiso-eu.com). This warranty does not cover: (1) Part failure due to normal wear or product abuse; (2) Any parts have been altered or modified by anyone other than an authorized Prexiso personnel or failure to install and operate equipment according to the guidelines put forth in the instruction manual. (3) Any products or parts used for rental purposes, damage resulting from shipping (claims must be filed with freighter), accident, abuse, act of God, misuse, or neglect. Prexiso will replace or repair the defective unit, at its option, subject to verification of the defect. Any implied warranties arising from the sale of a Prexiso product, including but not limited to implied warranties of merchantability and fitness for a particular purpose, are limited to the above. Prexiso shall not be liable for loss of use of the product or other incidental or consequential damages, expenses, or economic loss, or for any claim of such damage, expenses, or economic loss. This warranty excludes any accessories. This warranty gives you specific legal rights, and you may also have other rights that vary from state.

## Labelling

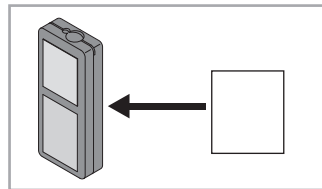

Subject to change (drawings, descriptions and technical data) without prior notice.

